

压式传感器 / Compression Force Sensor

LF-611

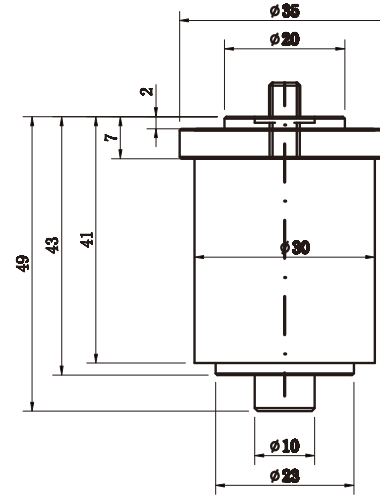
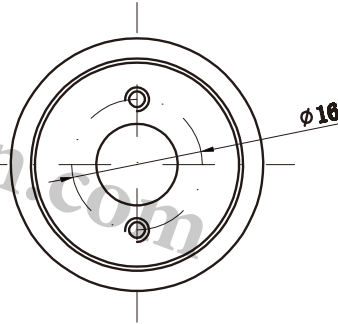

TECHNICAL SPECIFICATION

量程 Capacity	0~0.5,1,2,3,5,10,20,30,50kg	材质 Material	合金钢/不锈钢 Alloy steel / Stainless Steel
输出灵敏度 Rated Output	2.0 ± 10% mV/V	输出阻抗 Output Impedance	350 ± 3 Ω
零点输出 Zero Balance	± 2 % F.S.	绝缘电阻 Insulation	≥ 5000MΩ/100VDC
非线性 Non-linearity	0.05-0.1 % F.S.	使用电压 Recommended Excitation	3~10V
滞后 Hysteresis	0.05 % F.S.	最大使用电压 Maximum Excitation	15V
重复性 Repeatability	0.05 % F.S.	温度补偿范围 Compensated Temp Range	- 10 ~ 40 °C
蠕变 (30分钟) Creep (30min)	0.05 % F.S.	工作温度范围 Operating Temp Range	- 20 ~ 80 °C
温度灵敏度漂移 Temp Effect on Output	0.05 % F.S. / 10°C	安全超载 Safe Load Limit	150%
零点温度漂移 Temp Effect on Zero	0.05 % F.S. / 10°C	极限超载 Ultimate Load Limit	300%
输入阻抗 Input Impedance	385 ± 10Ω	电缆线尺寸 Cable Size	∅ 3 x 3m
电缆线连接方式 Wire Connection	Ex + : 红 Red; Ex - : 黑 Black; Sig + : 绿 Green; Sig - : 白 White		
主要应用 Applications	电子式注塑机, 冲击力检测设备, 气动液压设备等领域 Mainly applied in plastic shaped machines, and impact force test equipments, pneumatic hydraulic equipments and other fields		