

柱式传感器 / Column Force Sensor

LF-609

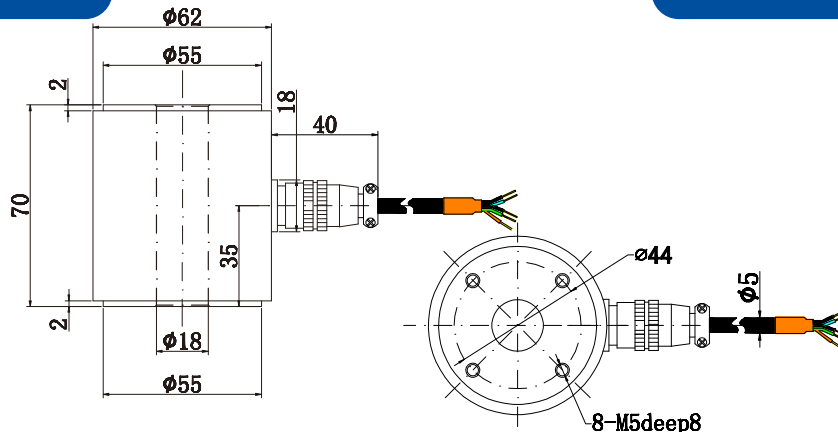
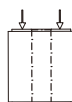

TECHNICAL SPECIFICATION

量程 Capacity	0-0.5,1,2,3,5,10t	材质 Material	不锈钢 Stainless steel
输出灵敏度 Rated Output	1.0-1.5 mV/V	输出阻抗 Output Impedance	700 ± 3Ω
零点输出 Zero Balance	± 2 % F.S.	绝缘电阻 Insulation	≥ 5000MΩ/100VDC
非线性 Non-linearity	0.5 % F.S.	使用电压 Recommended Excitation	10V
滞后 Hysteresis	0.5% F.S.	最大使用电压 Maximum Excitation	15V
重复性 Repeatability	0.5 % F.S.	温度补偿范围 Compensated Temp Range	- 10 ~ 60 °C
蠕变 (30分钟) Creep (30min)	0.05 % F.S.	工作温度范围 Operating Temp Range	- 20 ~ 80 °C
温度灵敏度漂移 Temp Effect on Output	0.05 % F.S. / 10°C	安全超载 Safe Load Limit	120%
零点温度漂移 Temp Effect on Zero	0.05 % F.S. / 10°C	极限超载 Ultimate Load Limit	150%
输入阻抗 Input Impedance	750 ± 5 Ω	电缆线尺寸 Cable Size	Ø5 X 3m
电缆线连接方式 Wire Connection	Ex + : Pin 1 Red; Ex - : Pin 2 Black; Sig + : Pin 3 Green; Sig - : Pin 4 White		
主要应用 Applications	过载能力强, 主要用研磨、抛光, 压装等领域的力值检测 Within good Overload ability, Mainly applied in force measurement of polishing, grinding and press assembling field.		